

EXPLANATION OF SPECIFICATIONS

Part Number:	The catalog number for the individual shock absorber.
Extended Length*:	The length of the shock absorber when it is fully extended. See "How to Measure" instructions.
Collapsed Length:	The length of the shock absorber when it is fully collapsed. See "How to Measure" instructions.
Stroke:	This is the approximate length of the stroke of the individual shock absorber being described.
Mounting Codes:	Indicates the type of mounting ends for the upper and lower end of each shock absorber. They are listed as follows: <ul style="list-style-type: none"> Stud type mounts ("S" & "DS") Eye ring and bushing mounts ("EB") Eye ring and bushing with sleeve mounts ("ES") Eye ring and bushing with bar pin mounts ("BP") Special mounting codes ("SP")

***NOTE: ALL DIMENSIONS SHOWN ARE IN INCHES - SEE CONVERSION CHARTS BELOW.**

CONVERSION CHART

Fraction (Inches)	Decimal (Inches)	Metric (MM)	Fraction (Inches)	Decimal (Inches)	Metric (MM)
1/64	0.016	0.397	33/64	0.516	13.097
1/32	0.031	0.794	17/32	0.531	13.494
3/64	0.047	1.191	35/64	0.547	13.891
1/16	0.063	1.588	9/16	0.563	14.288
5/64	0.078	1.984	37/64	0.578	14.684
3/32	0.094	2.381	19/32	0.594	15.081
7/64	0.109	2.778	39/64	0.609	15.478
1/8	0.125	3.175	5/8	0.625	15.875
9/64	0.141	3.572	41/64	0.641	16.272
5/32	0.156	3.969	21/32	0.656	16.669
11/64	0.172	4.366	43/64	0.672	17.066
3/16	0.188	4.763	11/16	0.688	17.463
13/64	0.203	5.159	45/64	0.703	17.859
7/32	0.219	5.556	23/32	0.719	18.256
15/64	0.234	5.953	47/64	0.734	18.653
1/4	0.250	6.350	3/4	0.750	19.050
17/64	0.266	6.747	49/64	0.766	19.447
9/32	0.281	7.144	25/32	0.781	19.844
19/64	0.297	7.541	51/64	0.797	20.241
5/16	0.313	7.938	13/16	0.813	20.638
21/64	0.328	8.334	53/64	0.828	21.034
11/32	0.344	8.731	27/32	0.844	21.431
23/64	0.359	9.128	55/64	0.859	21.828
3/8	0.375	9.525	7/8	0.875	22.225
25/64	0.391	9.922	57/64	0.891	22.622
13/32	0.406	10.319	29/32	0.906	23.019
27/64	0.422	10.716	59/64	0.922	23.416
7/16	0.438	11.113	15/16	0.938	23.813
29/64	0.453	11.509	61/64	0.953	24.209
15/32	0.469	11.906	31/32	0.969	24.606
31/64	0.484	12.303	63/64	0.984	25.003
1/2	0.500	12.700	1	1.000	25.400

METRIC CONVERSION CHART

MILLIMETERS	INCHES	MILLIMETERS	INCHES	MILLIMETERS	INCHES
1	0.03937	10	0.39370	19	0.74803
2	0.07874	11	0.43307	20	0.78740
3	0.11811	12	0.47244	21	0.82677
4	0.15748	13	0.51181	22	0.86614
5	0.19685	14	0.55118	23	0.90551
6	0.23622	15	0.59055	24	0.94488
7	0.27559	16	0.62992	25	0.98425
8	0.31496	17	0.66929		
9	0.35433	18	0.70866		

HOW TO MEASURE EXTENDED & COLLAPSED LENGTHS OF SHOCK ABSORBERS

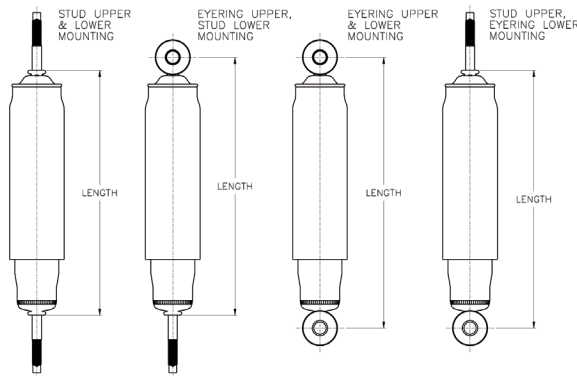

Instructions

1. Using the proper measuring points as shown above find the nearest replacement shock absorber from the listing increments of extended length.
2. Identify the proper mounting form the mounting codes and match these requirements by carefully measuring the mounting dimensions (top and bottom) of the shock absorber to be replaced.
3. Carefully take note of the following requirements:
 - a. **Mounting Accessories** - Contents and descriptions of parts are shown in this manual.
 - b. **Dust tubes** - This requirement should be noted in comparison with the shock absorber to be replaced. Shock absorber environment in its application makes this requirement necessary for piston rod protection and extended shock absorber life.
 - c. **Recoil Cutoff and Compression Bumper** - Carefully note these specifications- deviation of length requirements should not exceed $\pm 1/2"$. These shock absorber designs are footnoted for easy identification.
 - d. **Limited Environment Application** - Most conventional shock absorbers are offered in "straight" construction to fit limited environment applications. These shock absorber designs are footnoted.

SHOCK ABSORBER DIAMETERS

Shown below are measuring points for diameters by type of shock absorber. Refer to the chart below which lists diameters for the various bore sizes available for each type.

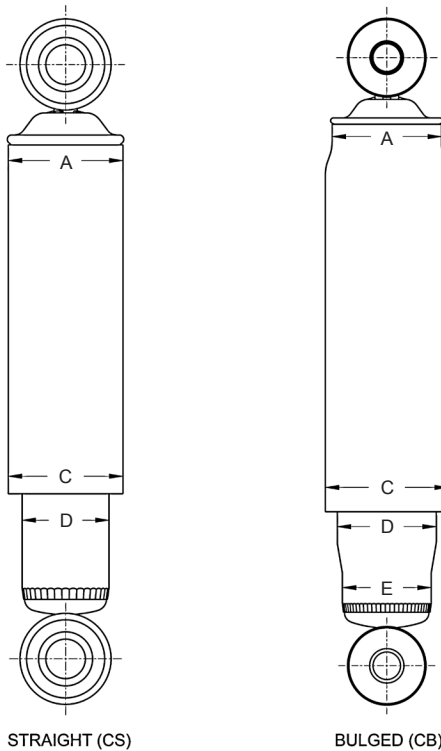

BORE SIZE	SHOCK ABSORBERS	TYPE (Shown Above)	Diameters				
			A	B	C	D	E
1 3/16"	Classic, Guardian, Ultra Pass. Car	CS	2.06	NA	2.00	1.63	NA
1 3/16"	Classic, Guardian, Ultra Pass. Car	CB	2.06	NA	2.19	1.81	1.63
1 3/8"	Ultra Truck	CS	NA	NA	2.37	2.00	NA
1 3/8"	Ultra Truck	CB	2.37	NA	2.50	2.19	2.00

Reference F

Reference F

MOUNTING CODE "CB" & "ES" EYE RING AND BUSHING WITH STEEL SLEEVE

TYPE 1 CENTERED IN EYE RING					TYPE 2 OFFSET IN EYE RING					TYPE 3 CAPTURED BUSHING				
MOUNTING CODE	TYPE	DIMENSION			MOUNTING CODE	TYPE	DIMENSION			MOUNTING CODE	TYPE	DIMENSION		
		A	B	C			A	B	C			A	B	C
CB2	3	1/2	1.43	-	ES46	2	12MM	1.88	0.62	ES135	2	12MM	1.77	-
CB3	3	1/2	1.58	-	ES47	1	8MM	1.25	-	ES136	1	5/8	1.75	-
CB4	3	9/16	1.67	-	ES52	1	12MM	1.19	-	ES137	1	1/2	1.73	-
CB5	3	12MM	1.48	-	ES53	1	10MM	1.38	-	ES138	1	5/8	1.70	-
CB6	3	10MM	1.59	-	ES54	1	12MM	2.91	-	ES139	1	12MM	1.35	-
CB7	3	12MM	2.15	-	ES56	1	14MM	1.58	-	ES140	1	16MM	1.78	-
CB8	3	1/2	2.15	-	ES57	1	10MM	1.03	-	ES141	1	12MM	1.61	-
ES1	1	10MM	1.25	-	ES58	1	7/16	2.44	-	ES142	1	16MM	1.43	-
ES2	1	10MM	1.42	-	ES59	1	3/8	1.82	-	ES143	1	9/16	1.60	-
ES3	1	10MM	1.56	-	ES60	1	14MM	1.26	-	ES144	1	9/16	1.97	-
ES4	1	10MM	1.97	-	ES61	1	12MM	1.76	-	ES145	1	7/16	2.25	-
ES5	1	10MM	2.07	-	ES62	1	12MM	0.98	-	ES146	1	12MM	1.37	-
ES7	1	10MM	2.65	-	ES65	1	12MM	1.38	-	ES147	1	12MM	1.97	-
ES8	1	7/16	1.25	-	ES69	1	12MM	1.58	-	ES148	1	3/4	1.56	-
ES9	1	7/16	1.31	-	ES73	1	5/8	1.32	-	ES149	1	1/2	2.36	-
ES10	1	7/16	1.38	-	ES78	1	10MM	1.92	-	ES150	1	3/4	2.24	-
ES11	1	7/16	1.50	-	ES83	1	12MM	1.48	-	ES152	1	20MM	1.69	-
ES12	1	7/16	1.62	-	ES84	1	10MM	1.62	-	ES153	1	14MM	1.55	-
ES14	1	7/16	1.88	-	ES85	1	12MM	2.36	-	ES157	2	1/2	2.05	0.953
ES16	1	7/16	3.15	-	ES88	1	12MM	1.81	-	ES158	2	14MM	1.89	-
ES17	1	12MM	1.25	-	ES90	1	5/8	2.00	-	ES159	1	14MM	1.77	-
ES18	1	12MM	1.65	-	ES91	1	1/2	2.10	-	ES160	1	5/8	1.25	-
ES19	1	12MM	1.88	-	ES94	1	1/2	2.15	-	ES161	1	16MM	2.75	-
ES20	1	12MM	1.95	-	ES98	1	12MM	2.20	-	ES162	1	12MM	2.75	0.67
ES21	1	12MM	2.28	-	ES102	1	10MM	1.77	-	ES163	3	1/2	2.20	-
ES22	1	1/2	1.25	-	ES104	1	20MM	1.58	-	ES165	2	15MM	2.28	-
ES23	1	1/2	1.31	-	ES105	1	8MM	1.80	-	ES166	1	16MM	1.97	-
ES24	1	1/2	1.38	-	ES106	1	10MM	1.48	-	ES167	1	16MM	2.60	-
ES25	1	1/2	1.50	-	ES107	1	12MM	2.15	-	ES168	1	16MM	3.94	-
ES26	1	1/2	1.56	-	ES109	1	10MM	0.95	-	ES169	1	1/2	1.19	-
ES27	1	1/2	1.62	-	ES110	1	16MM	1.61	-	ES171	1	14MM	1.48	-
ES31	1	1/2	2.25	1.00	ES111	1	9MM	1.78	-					
ES32	1	1/2	3.34	-	ES112	1	12MM	1.08	-					
ES34	1	9/16	1.66	-	ES113	1	16MM	1.49	-					
ES35	1	5/8	1.38	-	ES114	1	12MM	2.04	-					
ES36	1	3/4	1.75	-	ES118	1	12MM	1.31	-					
ES37	1	12MM	1.01	-	ES121	1	3/4	2.06	-					
ES38	1	7/16	2.18	-	ES122	1	10MM	1.26	-					
ES39	1	10MM	1.31	-	ES126	1	1/2	2.44	-					
ES40	1	7/16	3.38	-	ES127	1	7/8	1.75	-					
ES41	1	9MM	0.81	-	ES128	1	1/2	1.66	-					
ES44	1	10MM	2.28	-	ES132	1	9MM	1.50	-					
ES45	1	1/2	1.53	-	ES133	1	12MM	1.93	-					

MOUNTING CODE "SP" SPECIAL MOUNTS

<p>SP1</p>	<p>SP2A</p>	<p>APPLICATION USAGE FOR SPECIAL MOUNTING SHOWN AT LEFT.</p> <p>SP1 – MERCEDES-BENZ: FRONT LOWER MOUNT</p> <p>SP2A – EARLY FAIRLANE: FRONT LOWER MOUNT</p>
------------	-------------	--

MOUNTING CODE "DS" & "S" STUD MOUNTS

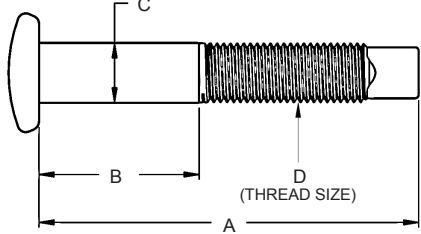
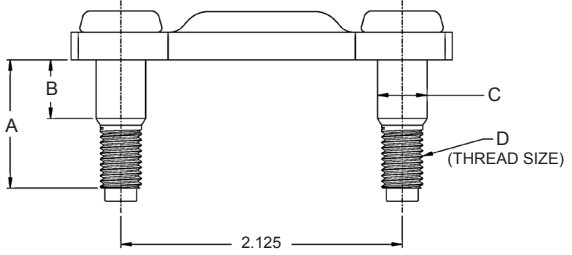
S					DS				
									
MOUNTING CODE	A	B	C	D	MOUNTING CODE	A	B	C	D
S1	2.37	1.00	3/8	3/8-24	S30	3.44	1.30	7/16	10MM
S2	2.06	1.00	3/8	3/8-24	S31	0.79	0.40	17MM	10MM
S3	1.04	0.65	3/8	3/8-24	S32	2.31	1.38	14MM	12MM
S4	1.85	1.00	3/8	3/8-24	S33	3.44	2.17	10MM	10MM
S6	2.47	1.47	7/16	3/8-24	S34	2.63	1.46	14MM	12MM
S7	1.97	1.00	3/8	3/8-24	S35	2.60	1.12	7/16	3/8-24
S12	2.37	1.15	7/16	3/8-24	S36	2.49	1.33	7/16	3/8-24
S16	2.95	1.45	16MM	16MM	S37	1.24	0.65	3/8	3/8-24
S17	2.15	1.03	7/16	3/8-24	S38	2.75	1.70	14MM	12MM
S20	2.67	1.56	11MM	3/8-24	S39	2.20	1.31	10MM	10MM
S21	3.28	1.75	5/8	5/8-18					
S29	2.99	1.87	3/8	3/8-24					

MOUNTING CODE "BP" EYE RING AND BUSHING WITH BAR PIN

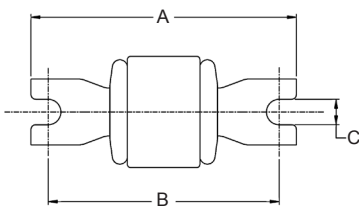
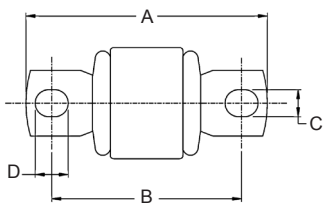
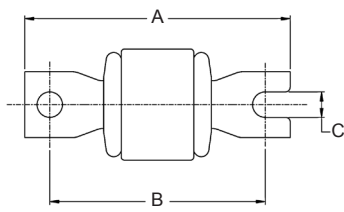
TYPE 1						TYPE 2						TYPE 3					
																	
MOUNTING CODE	TYPE	A	B	C	D	MOUNTING CODE	TYPE	A	B	C	D						
BP1	1	2.72	2.20	0.33	--	BP17	1	3.11	2.61	0.33	--						
BP3	1	2.82	2.38	0.33	--	BP18	1	3.75	3.14	0.39	--						
BP4	1	3.19	2.38	0.33	--	BP19	1	3.19	2.62	0.33	--						
BP5	1	3.19	2.75	0.33	--	BP20	1	3.59	3.12	0.33	--						
BP6	1	4.25	3.62	0.33	--	BP26	3	3.06	2.37	0.26	--						
BP7	2	3.13	2.50	0.35	0.42	BP27	2	4.00	2.95	0.52	--						
BP8	2	3.50	2.87	0.35	0.42	BP30	1	3.00	2.25	0.34	--						
BP11	1	2.96	2.52	0.33	--	BP31	3	3.50	2.87	0.35	--						
BP12	1	3.75	3.14	0.33	--	BP32	2	3.45	2.83	0.42	--						
BP13	1	3.45	3.00	0.33	--	BP33	2	4.44	3.62	0.39	0.47						
BP14	2	3.43	2.87	0.45	--	BP34	1	3.81	2.99	0.41	--						
BP16	2	3.70	2.91	0.35	0.49												

MOUNTING CODE "EB" EYE RING AND BUSHING

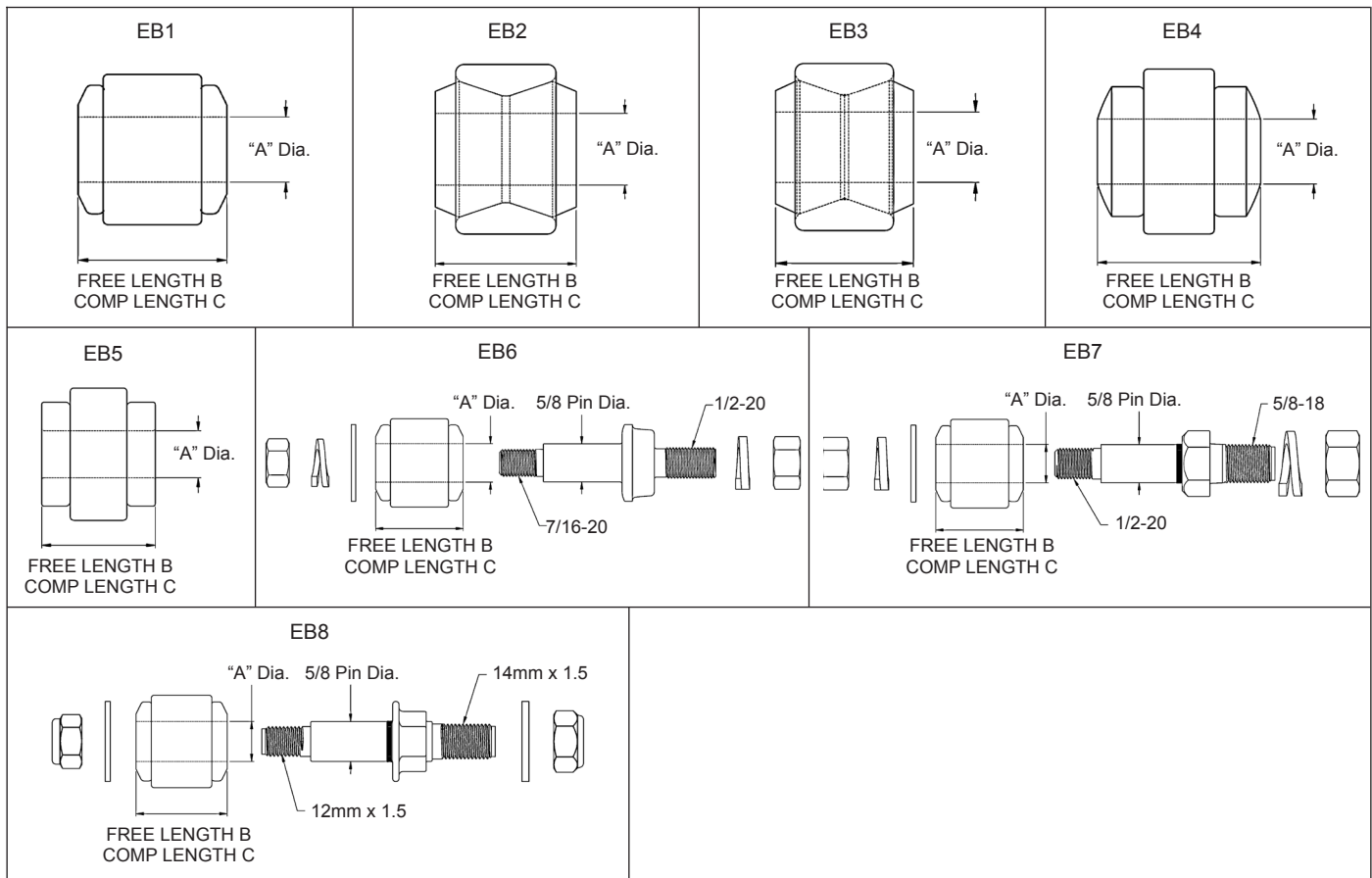

MOUNTING CODE	"A" Diameter	B Free Length	C Comp. Length	Vehicle Mounting Pin Dia.
EB1	5/8	1.44	1.31	5/8
EB2	3/4	1.75	1.50	3/4
EB3	1.00	1.91	1.75	1.00
EB4	11/16	1.72	1.55	11/16
EB5	5/8	1.51	1.25	5/8
EB6	5/8	1.44	1.31	Mounting pin furnished with shock absorber for 1/2 dia. vehicle mounting hole.
EB7	5/8	1.44	1.31	Mounting pin furnished with shock absorber for 5/8 dia. vehicle mounting hole.
EB8	5/8	1.44	1.31	Mounting pin furnished with shock absorber for 14mm dia. Vehicle mounting hole.